

ORIGAMI

von Peterpaul FORCHER
(Österreich)

Dez. 1997

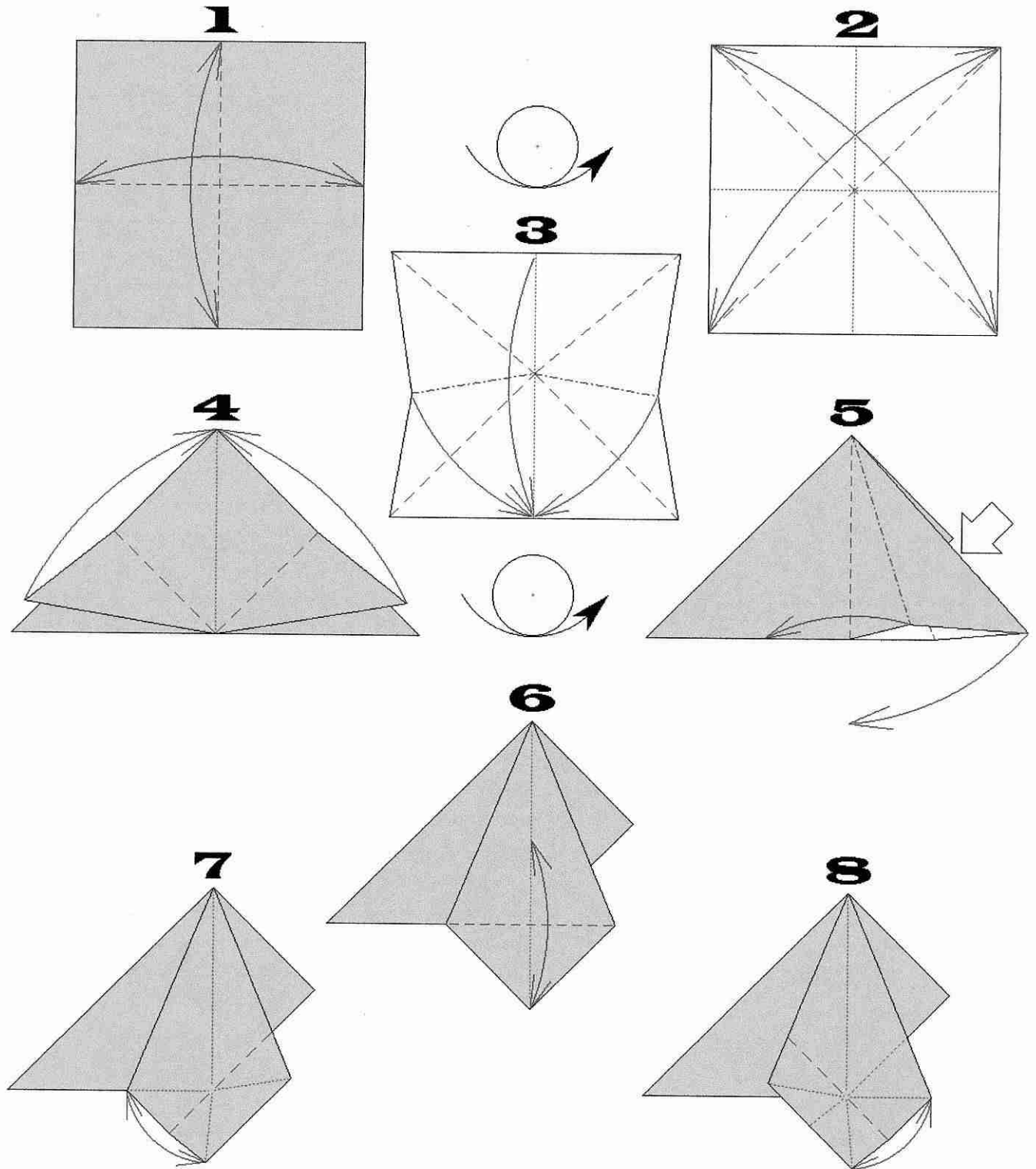

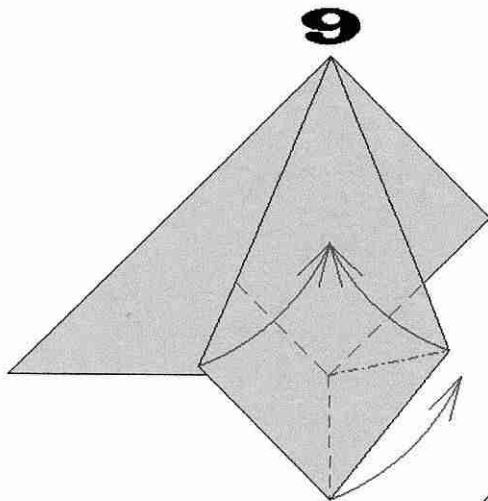

9

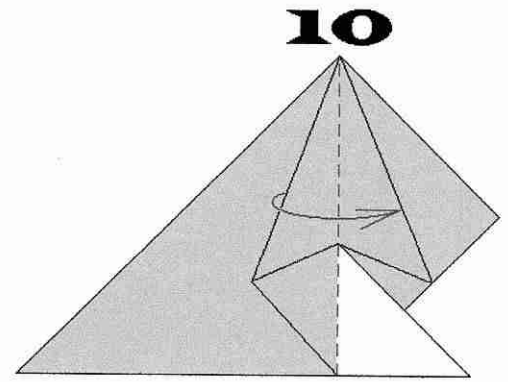

10

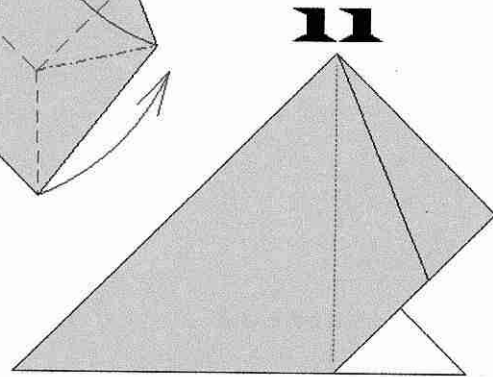

11

5 bis 10 auf der linken
Seite wiederholen!

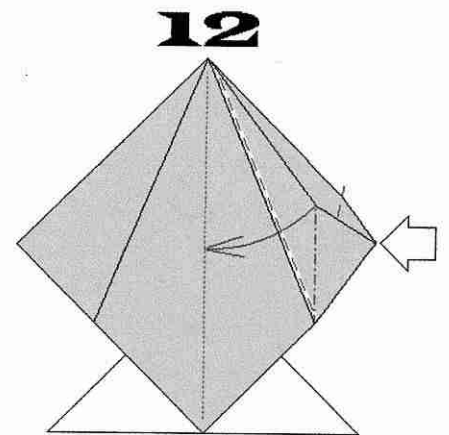

12

12 auf der linken
Seite wiederholen!

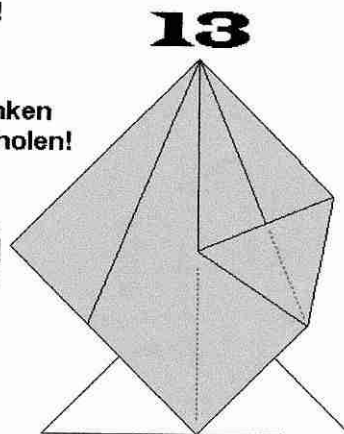

13

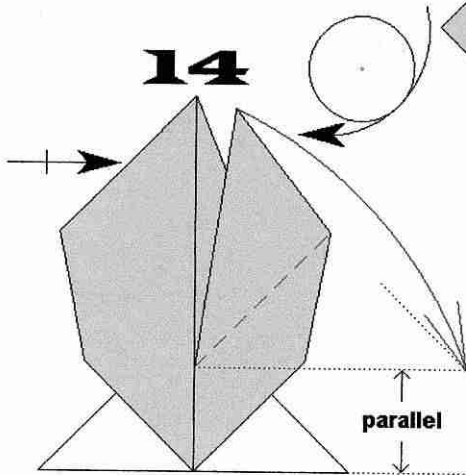

14

parallel

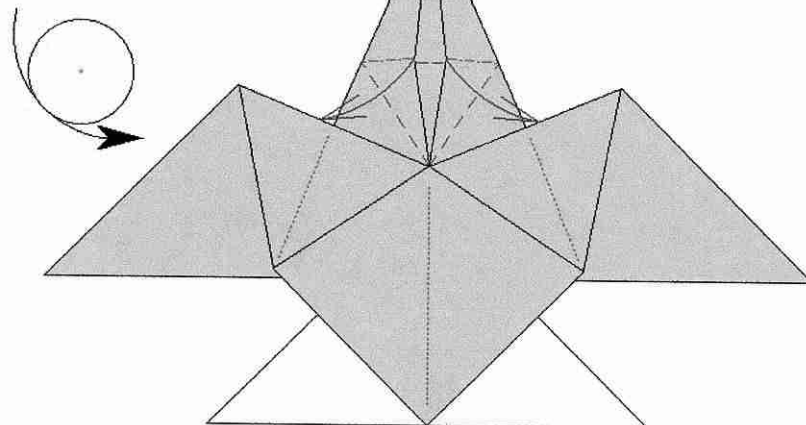

15

16

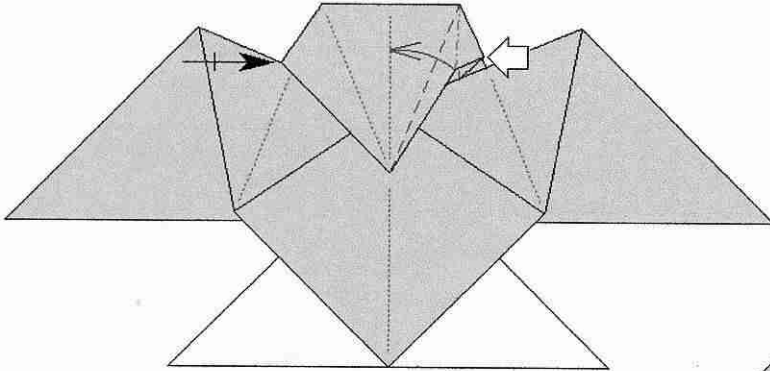

17

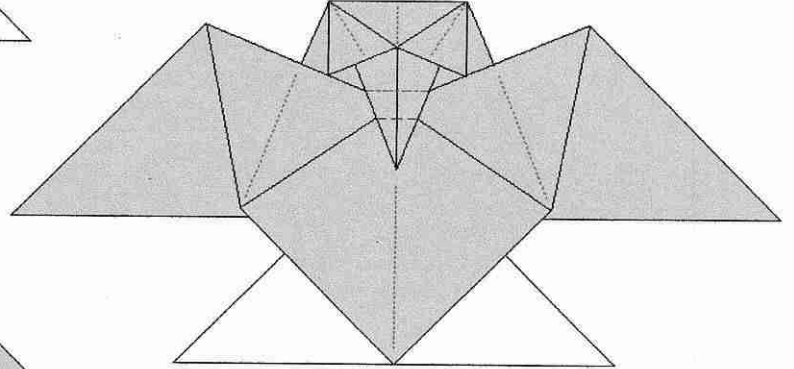

18

